

| PARTS LIST | | | | | | |
|------------|-----|-------------|--|---------|-------------|---------|
| ITEM | QTY | PART NO. | PART DESCRIPTION | LENGTH | UNIT WT. | NET WT. |
| 1 | 2 | X-CSRT-GP30 | 3" GUSSET PLATE | 12 in | 4.04 | 8.09 |
| 2 | 5 | G1205 | 1/2" x 5" HDG HEX BOLT GR5 FULL THREAD | 5 in | 0.33 | 1.63 |
| 3 | 10 | G12FW | 1/2" HDG USS FLATWASHER | 3/32 in | 0.03 | 0.34 |
| 4 | 5 | G12LW | 1/2" HDG LOCKWASHER | 1/8 in | 0.01 | 0.07 |
| 5 | 5 | G12NUT | 1/2" HDG HEAVY 2H HEX NUT | | 0.07 | 0.36 |
| | | | | | TOTAL WT. # | 10.49 |

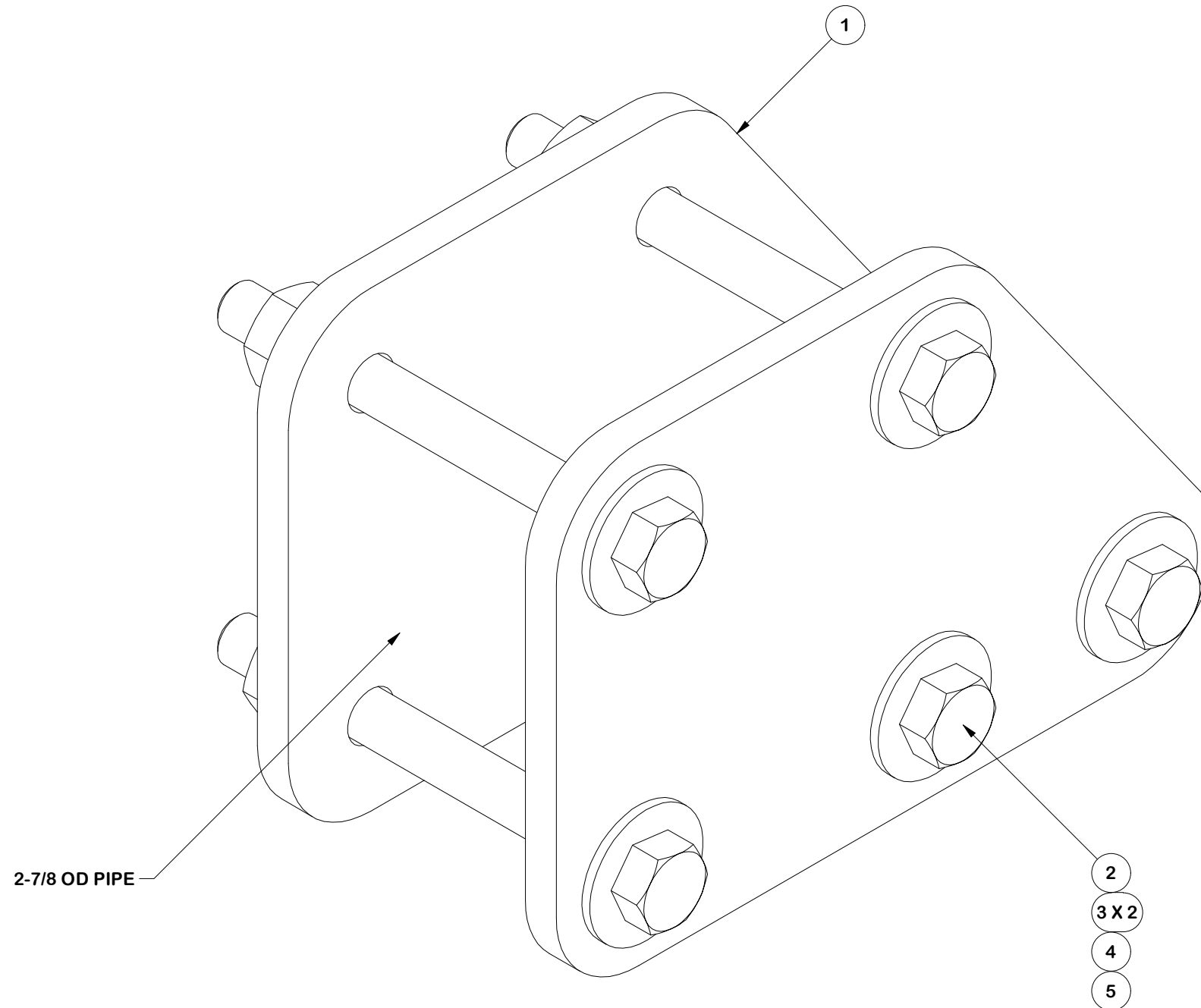

FINISH:
HOT DIP GALVANIZED.

TOLERANCE NOTES

TOLERANCES ON DIMENSIONS, UNLESS OTHERWISE NOTED ARE:
 SAWED, SHEARED AND GAS CUT EDGES ($\pm 0.030"$)
 DRILLED AND GAS CUT HOLES ($\pm 0.030"$) - NO CONING OF HOLES
 LASER CUT EDGES AND HOLES ($\pm 0.010"$) - NO CONING OF HOLES
 BENDS AND ANGLES ARE $\pm 1/2$ DEGREE
 ALL OTHER MACHINING ($\pm 0.030"$)
 ALL OTHER ASSEMBLY ($\pm 0.060"$)

PATENT INFORMATION: WWW.SITEPRO1.COM/PATENTS

PROPRIETARY NOTE:
 THE DATA AND TECHNIQUES CONTAINED IN THIS DRAWING ARE PROPRIETARY INFORMATION OF VALMONT INDUSTRIES AND CONSIDERED A TRADE SECRET. ANY USE OR DISCLOSURE WITHOUT THE CONSENT OF VALMONT INDUSTRIES IS STRICTLY PROHIBITED.

DESCRIPTION
CSRT GUSSET PLATE KIT

| | | |
|-----------------------|-------------------------------------|------------------------------------|
| CPD NO. SP1 | DRAWN BY ADB 12/2/2024 | ENG. APPROVAL 12/30/2024 |
| CLASS 87 | SUB 02 | DRAWING USAGE CUSTOMER |
| | CHECKED BY JET 12/30/2024 | |

SITE PRO 1
 A valmont COMPANY

Engineering Support Team:
 sp1engineering@valmont.com

| |
|------------------------------|
| PART NO. CSRT-GP30 |
| DWG. NO. CSRT-GP30 |